

OPENAMPERe
A cooperation between ITI & Powerspec Inc.
INNOVATIVE~FLEXIBLE~COMPACT

User Manual WIP



• Table of Contents	2
• Overview	4
• Safety Precautions	5
• Installation	5
• Front Panel Controls, Ports, and Indicators	6
Main Power Switch	6
Main Power Indicator	6
Outputs Enabled Indicator	7
Emergency Stop Switch	7
Circuit Breaker	7
SBC Ethernet Port	7
SBC HDMI Port	7
SBC USB Ports 1 and 2	7
PBE MCU USB Port	7
Feeder Protection RElay Connectors	8
• Rear Panel	8
Ventilation Slots	8
Mains Inlet	8
• Controlling the PBE Via Software	9
• Maintenance	9
Fan Filters	9
Accessing the SBC	9

- **Appendix 2. SBC I/O Connections10**
 - SBC Channel Control12
 - SPI Clocking Mode12
 - Notes Regarding Parameter Values12
 - SPI Channel Control Message Format13
 - Channel Control Message Command Byte14
 - Channel Controller Status Message14

- **Appendix 3. Feeder Protection Relay Connector Pinou.....15**

- **Appendix 4. Specifications16**
 - Breaker Voltage Outputs16
 - Breaker Current Outputs17
 - Breaker Status Outputs17
 - Breaker Control Inputs17
 - System Timing18
 - Power Input19
 - Cooling19
 - Environmental19
 - Physical20
 - Revision History20



The Power Box Emulator emulates four circuit breakers in conjunction with one or more Feeder Protection Relays. Each of the four breaker positions supplies four AC current outputs, five AC voltage outputs, and two 120VAC status outputs to a relay, and accepts three dry-contact inputs from the relay.

The system is controlled by an internal single-board computer (SBC) which has external ethernet and USB connectivity. It can also be controlled from an external PC via USB.

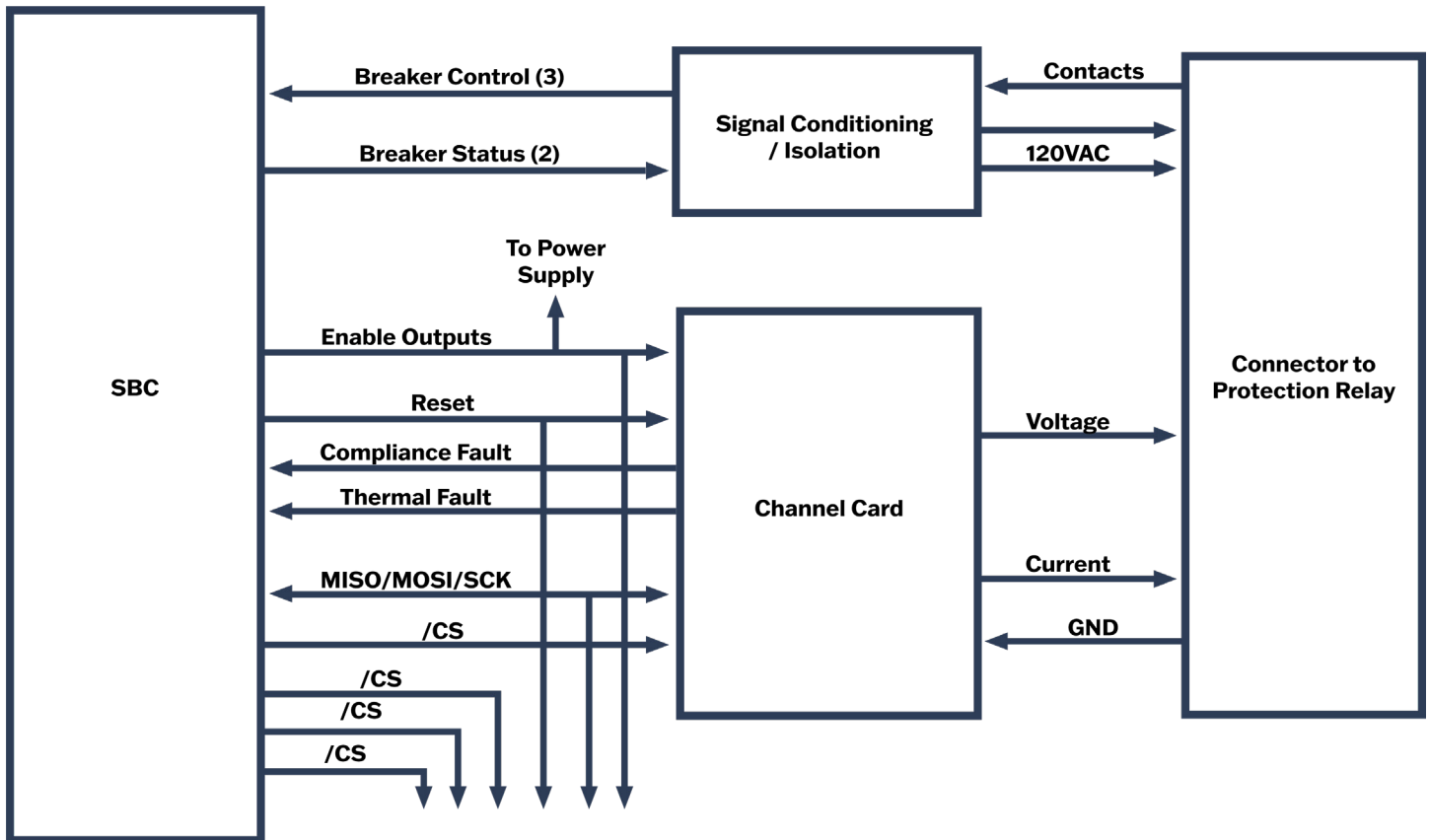

SAFETY PRECAUTIONS



The Power Box Emulator outputs hazardous voltage up to 240VACpk / 170Vrms AC voltage at its output terminals when operating. Output connections should never be handled when the PBE is operating, and proper connection and insulation practices observed.



The Power Box Emulator generates hazardous voltages internally of up to 435VACpk / 307VACrms and ± 385 VDC. Stored energy is present in the DC circuitry that can maintain hazardous voltage levels for up to 30 seconds after mains power is removed. The enclosure should never be opened by untrained personnel.



The Protection Relay connectors incorporate protective earthing/bonding contacts in addition to their signal contacts. These contacts are connected to the mains PE via the PBE's grounded line cord. It is essential to safe operation of the device that cables connecting the PBE to external equipment such as Protection Relays include an equipment bonding conductor joining the protective earth terminals (i.e. the enclosures) of the devices.

INSTALLATION



The PBE is heavy and if rack-mounted must be securely installed in a sturdy rack capable of supporting its weight.



The flow of cooling air through the PBE must be unimpeded, i.e. the air exhaust from the rear ventilation slots must be able to freely flow to the ambient environment.



The PBE must be powered from a properly-grounded mains supply using a 3-wire power cord.

- **Mains Power Switch**

Master toggle power switch connecting mains power to the PBE. This may be removed in production, as it is redundant with the Emergency Stop switch.

- **Mains Power Indicator**

Illuminates when mains power is present after the Mains Power Switch, Emergency Stop Switch, and Circuit breaker.

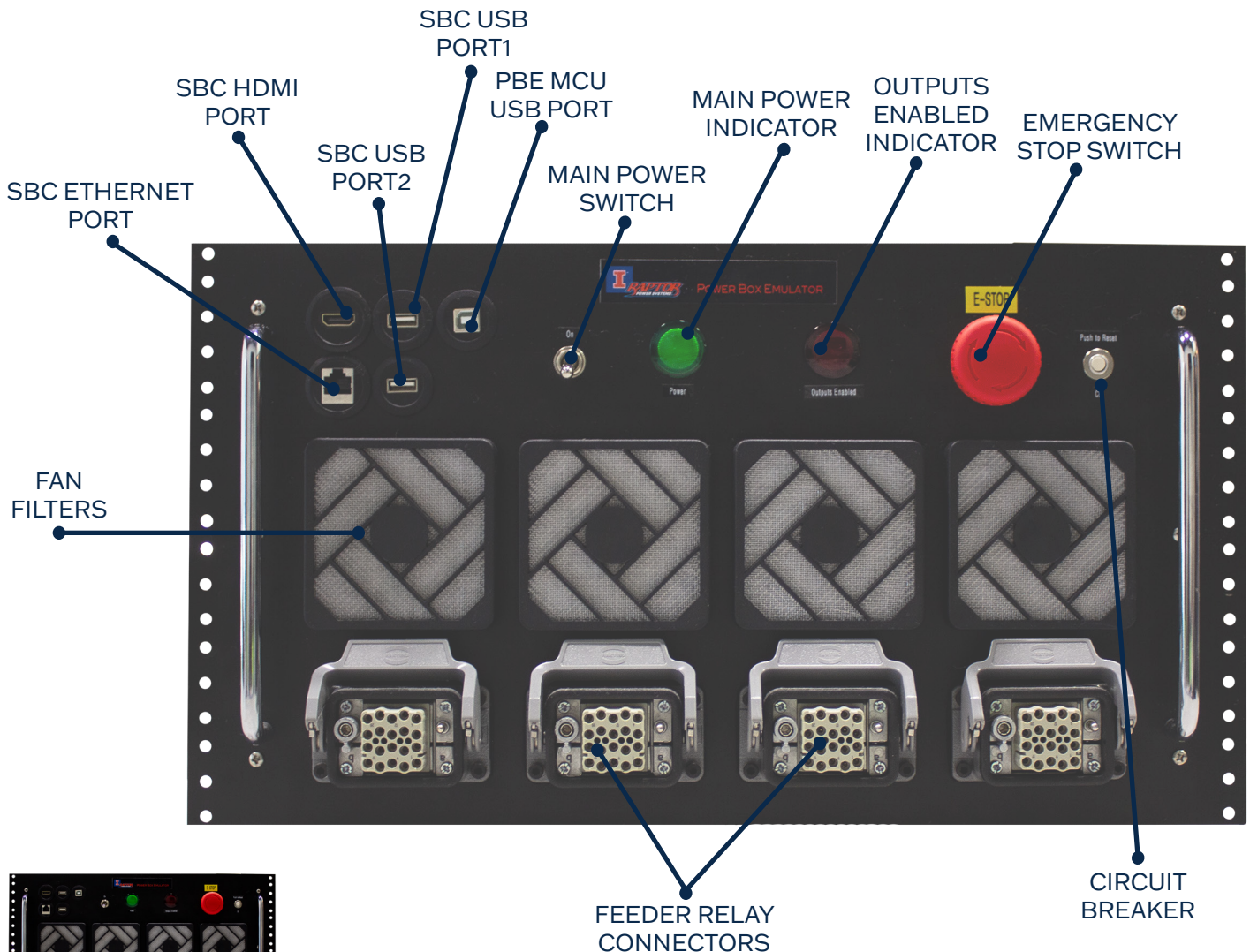

- **Outputs Enabled Indicator**

Illuminates when the voltage outputs are connected to the Feeder Relay connectors and hazardous voltage may be present on the outputs. In production, disabling the outputs will also disconnect the current sources from the Feeder Relay connectors, but in the prototypes this is not the case. A “virtual disconnect” for the current sources can be achieved by setting the amplitude of all current sources to zero.

- **Emergency Stop Switch**

When depressed, removes AC mains power from the PBE and disconnects the high-voltage power supply (which has capacitors that can store potentially lethal charge for up to 30 seconds) from the signal generators. After pressing the Emergency Stop switch, rotate it clockwise to turn the system back on.

- **Circuit Breaker**

Push-to-reset breaker on AC mains input.

- **SBC Ethernet Port**

Connects to the SBC’s ethernet port.

- **SBC HDMI Port**

Connects to one of the SBC’s HDMI ports.

- **SBC USB Ports 1 and 2**

USB Type A host ports connecting to USB host ports of the SBC.

- **PBE MCU USB Port**

USB type B peripheral port allows control of the system via the internal microcontroller and PC host application.

- **Feeder Protection Relay Connectors**

20-pin Harting Han EE connectors, one for each channel, connect the PBE to feeder protection relays. The pinout of these connectors is specified elsewhere in this document. In addition to the 20 signal pins, each of these connectors provides a protective earth / bonding conductor which must be connected to external equipment to ensure safety.

- **Rear Panel**



- **Ventilation Slots**



The rear panel incorporates ventilation slots for the exit of cooling air. The ventilation slots must never be blocked or enclosed.

- **Main Inlet**

Appliance inlet accepting a standard C13 mains cable for delivering 120VAC to the PBE



The PBE must be powered from a properly-grounded mains supply using a 3-wire power cord.

- **Controlling the PBE Via Software**

The PBE has no hardware controls other than the mains power switching described above – all operational parameters and functions are controlled by either the internal SBC or by an external PC in communication with the PBE’s internal microcontroller. A software utility is available for the latter scenario and is documented in its own User Manual.

It is strongly recommended that the system reset line be asserted after power-up before further usage of the PBE, in order to ensure that all channel cards are properly initialized.

It is strongly recommended that an Align Phases command be issued to each channel after power-up before further usage of the PBE in order to ensure phase alignment between the signal generators of each channel..

Maintenance

- **Fan Filters**

The fan filters should be inspected periodically (at a minimum, after every 1,000 hours of operation) and examined for dust buildup. If significant dust is present that could reduce airflow, the filter(s) should be cleaned or replaced. To inspect/replace the filters, pry off the outer filter retainer at the fan inlet. After inspection/cleaning/replacement, snap the retainer back on.

- **Accessing the SBC**

It may be necessary at times to access the SBC for memory card formatting, replacement, and so forth.



This requires opening the PBE enclosure and should not be undertaken without further explicit instruction from and supervision by Powerspec.

Name	Rasp Pi GPIO Header Pin	GPIO/12C Port #	Direction	Active Polarity	Description
SCLK	23	GPIO11	Output	Idle High, clock out MOSI on HIGH > LOW, sample MISO on LOW > HIGH	SPI Clock
MOSI	19	GPIO 10	Output	Idle HIGH	SPI data from SBC to channel
MISO	21	GPIO 9	Input	Idle HIGH	SPI data from channel to SBC
/CS1	7	GPIO 4	Output	LOW	Select Channel 1
/CS2	11	GPIO 17	Output	LOW	Select Channel 2
/CS3	13	GPIO 27	Output	LOW	Select Channel 3
/CS4	15	GPIO 22	Output	LOW	Select Channel 4
RESET	VIA 12C	PO2	Output	HIGH	Reset all channel controller MCUs
ENABLE	VIA 12C	PO1	Output	HIGH	Enable/Disable all outputs, including 120V Control Voltage
TFAULT1	VIA 12C	PO6	Input	HIGH	Channel current source thermal fault, channel has auto-disabled all outputs
TFAULT2	VIA 12C	PO5	Input	HIGH	Channel current source thermal fault, channel has auto-disabled all outputs
TFAULT3	VIA 12C	PO4	Input	HIGH	Channel current source thermal fault, channel has auto-disabled all outputs
TFAULT4	VIA 12C	PO3	Input	HIGH	Channel current source thermal fault, channel has auto-disabled all outputs
CFAULT1	10	GPIO 15	Input	HIGH	Channel current source compliance fault, current source not disabled
CFAULT2	12	GPIO 18	Input	HIGH	Channel current source compliance fault, current source not disabled
CFAULT3	16	GPIO 23	Input	HIGH	Channel current source compliance fault, current source not disabled
CFAULT4	18	GPIO 24	Input	HIGH	Channel current source compliance fault, current source not disabled
OPEN1	29	GPIO 5	Input	HIGH	Relay Contact is Closed
CLOSE1	31	GPIO 6	Input	HIGH	Relay Contact is Closed
AUX1	33	GPIO 13	Input	HIGH	Relay Contact is Closed
OPEN2	35	GPIO 19	Input	HIGH	Relay Contact is Closed
CLOSE2	37	GPIO 26	Input	HIGH	Relay Contact is Closed
AUX2	22	GPIO 25	Input	HIGH	Relay Contact is Closed
OPEN3	24	GPIO 8	Input	HIGH	Relay Contact is Closed
CLOSE3	26	GPIO 7	Input	HIGH	Relay Contact is Closed
AUX3	32	GPIO 12	Input	HIGH	Relay Contact is Closed

Name	Rasp Pi GPIO Header Pin	GPIO/12C Port #	Direction	Active Polarity	Description
OPEN4	36	GPIO 16	Input	HIGH	Relay Contact is Closed
CLOSE4	38	GPIO 20	Input	HIGH	Relay Contact is Closed
AUX4	40	GPIO 21	Input	HIGH	Relay Contact is Closed
STATUS_OUT1	VIA 12C	P10	Output	HIGH	Breaker Status Output
AUX_OUT1	VIA 12C	P11	Output	HIGH	Breaker Auxiliary Output
STATUS_OUT2	VIA 12C	P12	Output	HIGH	Breaker Status Output
AUX_OUT2	VIA 12C	P13	Output	HIGH	Breaker Auxiliary Output
STATUS_OUT3	VIA 12C	P14	Output	HIGH	Breaker Status Output
AUX_OUT3	VIA 12C	P15	Output	HIGH	Breaker Auxiliary Output
STATUS_OUT4	VIA 12C	P16	Output	HIGH	Breaker status Output
AUX_OUT4	VIA 12C	P17	Output	HIGH	Breaker Auxiliary Output
120V GOOD	VIA 12C	PO0	Input	HIGH	120V Control Voltage is Present
SDA	3	GPIO 2	Bidirectional		I/O Expander 12C
SCL	5	GPIO 3	Output		I/O Expander 12C
/INT	8	GPIO 14	Input	LOW	Interrupt generated when any 12C input pin changes state; de-asserts when port is read or returns to original state.

Note that binary I/O does not function unless ENABLE is active, because for safety reasons the 120V Control Voltage excitation is controlled by the ENABLE line.

The I/O expander's I2C address is 0x20.

- **SBC Channel Control**

The SBC controls the Channel Controllers by writing a sequence of bytes directly to a channel controller's memory via a four-wire SPI (serial peripheral interchange) bus. Each channel controller has its own "chip select" line that is asserted by the SBC; all controllers share the SPI clock (SCK), MISO and MOSI lines.

- **SPI Clocking Mode**

The SPI bus operates in "Mode 3", i.e. the idle state for SCK is logic high, and data is transferred out of the shift register on falling clock edges (idle to active transitions). Returned data from channel controllers should be sampled on rising edges of SCK (active to idle transitions).

- **Notes Regarding Parameter Values**

It is the SBC host's responsibility to check that transmitted amplitude parameters are within valid limits. Voltages in excess of 150Vrms will result in clipped output waveforms, and currents in excess of 5A may cause clipping and/or thermal faults in the current source(s).

Phase values are checked by the signal generator; values above 359.9° are treated as 0°.

All frequency values are permitted, however a frequency of 0 will leave the output voltage or current at a steady-state DC level of the instantaneous voltage present when the 0 frequency parameter was received.

Byte Offset in Message	Bytes	Function	Valid Range	Unit
0	2	Voltage A Frequency	1-65, 535	5mHZ
1	2	Voltage B Frequency	1-65, 535	5mHZ
2	2	Voltage C Frequency	1-65, 535	5mHZ
3	2	Voltage N Frequency	1-65, 535	5mHZ
4	2	Current N Frequency	1-65, 535	5mHZ
5	2	Current A Frequency	1-65, 535	5mHZ
6	2	Current B Frequency	1-65, 535	5mHZ
7	2	Current C Frequency	1-65, 535	5mHZ
8	2	Voltage S Frequency	1-65, 535	5mHZ
9	2	Voltage A Phase	0-3, 599	0.1°
10	2	Voltage B Phase	0-3, 599	0.1°
11	2	Voltage C Phase	0-3, 599	0.1°
12	2	Voltage N Phase	0-3, 599	0.1°
13	2	Current N Phase	0-3, 599	0.1°
14	2	Current A Phase	0-3, 599	0.1°
15	2	Current B Phase	0-3, 599	0.1°
16	2	Current C Phase	0-3, 599	0.1°
17	2	Voltage S Phase	0-3, 599	0.1°
18	2	Voltage A Amplitude	0 - 60, 222	2.49078mV
19	2	Voltage B Amplitude	0 - 60, 222	2.49078mV
20	2	Voltage C Amplitude	0 - 60, 222	2.49078mV
21	2	Voltage N Amplitude	0 - 60, 222	2.49078mV
22	2	Current N Amplitude	0 - 49, 984	100.033μA
23	2	Current A Amplitude	0 - 49, 984	100.033μA
24	2	Current B Amplitude	0 - 49, 984	100.033μA
25	2	Current C Amplitude	0 - 49, 984	100.033μA
26	2	Voltage S Amplitude	0 - 60, 222	2.49078mV
27	1	Channel Command		See Following

- **SPI Channel Control Message Format**

The following 55 bytes must all be sent with each transmission. Note that the data is little-endian; each word must be transmitted LSB-first.

- **Channel Control Message Command Byte**

The last byte of the 55-byte Channel Control Message is a Command byte. By writing bits to the command byte the SBC can control functions of the channel controllers that are not supported by dedicated hardware lines. At present the only command implemented is Align Phase..

7	6	5	4	3	2	1	0
X	X	X	X	X	X	X	Align Phase

When the channel controller detects the Align Phase bit of the command byte high, it sets the phase accumulators of all signal generators to zero. The Align Phase command is treated as a “one-shot” command; it is executed once only for each reception of the command.

It is strongly recommended that an Align Phase command be issued to each channel after power-up before further usage of the PBE in order to ensure phase alignment between the signal generators of each channel.

- **Channel Controller Status Message**

A Status Byte is transmitted repeatedly by a channel controller via SPI as each byte of a Channel Control Message is received. By examining the contents of the Status Byte, the SBC can determine on which phase(s) compliance or temperature faults are present.

7	6	5	4	3	2	1	0
N Phase Current Source Temperature Fault	C Phase Current Source Temperature Fault	B Phase Current Source Temperature Fault	Aw Phase Current Source Temperature Fault	N Phase Current Source Compliance Fault	C Phase Current Source Compliance Fault	B Phase Current Source Compliance Fault	A Phase Current Source Compliance Fault

APPENDIX 3. FEEDER PROTECTION RELAY CONNECTOR PINOUT

Harting EE Connector Pin	Function	Comments
1	C Phase Current Output	
2	B Phase Current Output	
3	A Phase Current Output	
4	C Phase Voltage Output	
5	A Phase Voltage Output	
6	N Voltage Output	
7	Current Outputs Return Current	
8	"S" Voltage Output	
9	Voltage Outputs GND	
10	120V Control Voltage L	L side of 120 VAC (nominal) excitation for binary O/I
11	unused	
12	unused	
13	OPEN Input	Relay contact closure to 120V Control Voltage L tells breaker to open.
14	CLOSE Input	Relay contact closure to 120V Control Voltage L tells breaker to close.
15	B Phase Voltage Output	
16	N Current Output	
17	Breaker Status 52A	Output driven by 120V Control Voltage L
18	120V Control Voltage N	N side of 120V excitation source
19	Breaker Aux Output 1	Output driven by 120V Control Voltage L. Not in UI Connect, but in the PBE spec.
20	Breaker Aux Input	Relay contact closure to 120V Control Voltage L. Not in UI Connect, but in the PBE spec.

Pinout of the relay connectors has not yet been finalized;
the table above is provisional.

- **Breaker Voltage Outputs**

Parameter	Min	Typ	Max	Unit
Output Voltage	0		150	VRMS
Control Word Size		16 ¹		Bits
Voltage Step Size @60Hz		2.48829		mVRMS per step
Amplitude Error @60Hz		0.1	±1	%
Amplitude Error 30-240Hz			±2.5	%
DC Offset			0.5	V
Output Current			10	mA
Overcurrent Limiting		28		mA
Frequency	.005		328	Hz
Frequency Control Word Size		16		Bits
Frequency Step Size		.005 ²		Hz
Frequency Accuracy			555	ppm
Phase Offset	0		359.9	Degrees
Phase Control Word Size		16 ³		Bits
Phase Offset Step Size		0.1		Degrees
Total Harmonic Distortion			1	Percent

1. Valid value range is 0-60,222
2. Finer resolution is possible, but 5mHz was requested.
3. Valid value range is 0-3,599

• Breaker Current Outputs

Parameter	Min	Typ	Max	Unit
Output Voltage	0		5	ARMS
Control Word Size		16 ¹		Bits
Voltage Step Size @60Hz		99.933		μARMS per step
Amplitude Error @60Hz		0.5	±2	%
Amplitude Error 30-240Hz			±3.5	%
DC Offset			24	mA
Compliance			140	mΩ total connected external resistance
Frequency	.005		328	Hz
Frequency Control Word Size		16		Bits
Frequency Step Size		.005 ²		Hz
Frequency Accuracy			555	ppm
Phase Offset	0		359.9	Degrees
Phase Control Word Size		16 ³		Bits
Phase Offset Step Size		0.1		Degrees
Total Harmonic Distortion			1	Percent

1. Valid value range is 0-49,984
2. Finer resolution is possible, but 5mHz was requested.
3. Valid value range is 0-3,599

• Breaker Status Outputs

Parameter	Min	Typ	Max	Unit
Output Voltage	100 ¹	140 ²	160 ³	VAC _{RMS}
Overcurrent Protection Threshold		300		mA Primary Current

1. 4mA load on each of the 8 outputs, all 12 inputs closed, 108VAC line voltage
2. 2mA load on half of the outputs, half of the inputs closed, 120VAC line voltage
3. All outputs off, all inputs open, 132VAC line voltage

• Breaker Control Inputs

Parameter	Min	Typ	Max	Unit
Response Time, Open->Close			8.3	ms
Response Time, Close->Open			150	ms

- **System Timing**

Parameter	Min	Typ	Max	Unit
SBC SPI Clock Frequency			5	MHz
Control Word Transmission time, one channel, @max clock		88		µs
Control Word Transmission time, four channels, @max clock		352		µs
Latency from control word transmission complete to output change		28		µs

- **Power Input**

Parameter	Min	Typ	Max	Unit
Input Voltage			5	MHz
Frequency		88		µs
Power Consumption		352		µs

- **Cooling**

Parameter	Min	Typ	Max	Unit
Number of Fans			5	MHz
Bearing Type		88		µs
Approximate Total Airflow Under Full Load at TA = 20C		352		µs
Temperature-Controlled Fan Speed		28		µs

- **Environmental**

Parameter	Min	Typ	Max	Unit
Ambient Temperature			5	MHz
Humidity		88		µs
Altitude		352		µs

- **Physical**

Parameter	Typ	Max	Unit
Weight	38	Lb	
Weight	17.23	kg	
Dimensions	19W x 18D x 10.5H	in	Depth includes controls
Dimensions	48.26W x 45.72D x 26.7H	cm	

- **Revision History**

Revision No.	Date	Description
1	26 Mar 2021	First release, based on Specifications document Rev 7

